

Especificidades das arquiteturas dos veículos elétricos e híbridos Plug-In



Joaquim Delgado

Escola Superior de Tecnologia e Gestão de Viseu

25 de outubro de 2017

1. Breve história do automóvel elétrico
2. Necessidades de autonomia
3. Pontos fracos
 - ✓ Autonomia
 - ✓ Rapidez da recarga
 - ✓ Custo
4. Principais arquiteturas dos veículos elétricos e híbridos
 - ✓ Tradicional com MCI
 - ✓ HEV
 - ✓ PHEV (paralelo e série)
 - ✓ BEV
 - ✓ *Mild Hybrid*

1. Breve história do automóvel elétrico

- A descoberta da bateria e do motor elétrico são anteriores à do motor de combustão interna e os primeiros veículos **(auto)móveis** foram elétricos (Moses Fanner em 1847).
- Entre 1890 e 1938, foram produzidos só nos EUA mais de 100.000 VE por 33 empresas, com o pico em 1912 (34.000 unidades).
- Nessa altura só havia eletricidade e estradas pavimentadas nas áreas urbanas e as distâncias a percorrer eram curtas.
- Segurança, facilidade de condução, baixo ruído e vibração e elevada fiabilidade constituíam fatores de decisão de compra do VE.

Primeiros auto(móveis) foram elétricos



1884 – Primeiro VE, Thomas Parker - UK.



1900 – (Waldmar Jungner) Suécia, 150 km.



1900 - VE de Ferdinand Porsche

J. Delgado - ESTGV



1906 Krieger Electric Landulet - USA

Fatores para abandono do VE

- Falta de eletricidade nas zonas rurais, construção de estradas entre cidades, descoberta de petróleo na Pensilvânia e melhorias introduzidas no MCI que permitiam maior autonomia e custos competitivos.
- Ironicamente é com o uso de um motor elétrico e uma bateria (arranque elétrico) no MCI que, em 1912-1914, é dado um grande salto na utilidade da tecnologia de combustão.
- A partir de 1910, com o crude a cerca de \$2 dólares por barril e a cooperação entre empresas petrolíferas e automóveis, a tecnologia do MCI alcança vantagens que **induzem o coma nos VE's**.

Os níveis de emissões só podem ser eficazmente reduzidos com uma diminuição drástica no consumo de energia de origem fóssil!

- A **ligação do sector dos transportes ao petróleo tem que ser mitigada** e isso implica um **novo paradigma energético** que seja simultaneamente:
 - Mais eficiente;
 - Sustentável;
 - Compatível com um futuro assente em energia renovável.

2. Necessidades de autonomia

77% dos utilizadores do estudo percorreram uma distância diária inferior a 50 km, enquanto que 93% percorrem uma distância diária inferior a 100km.

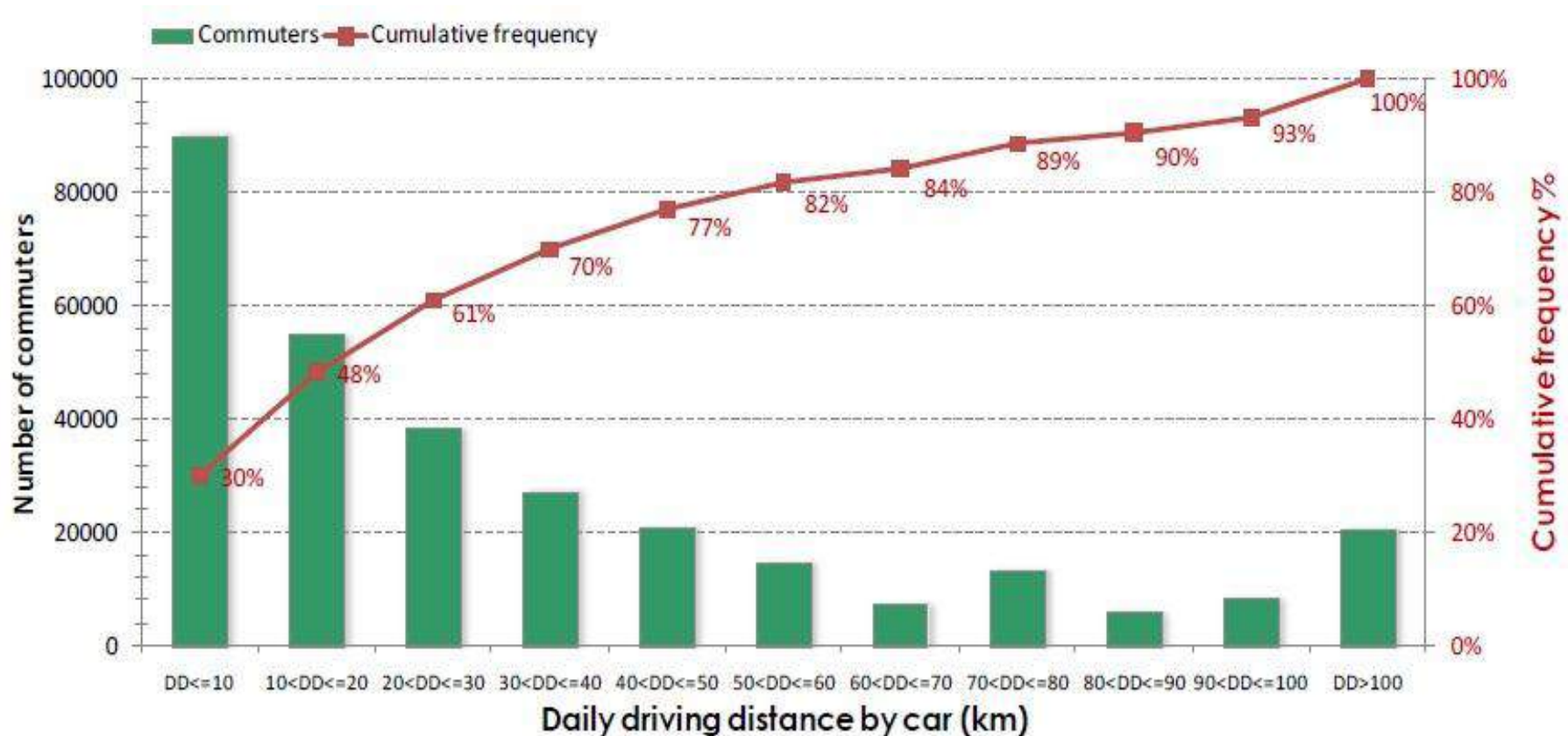

Distâncias médias percorridas por automóveis, em Portugal [2013].

Autonomias

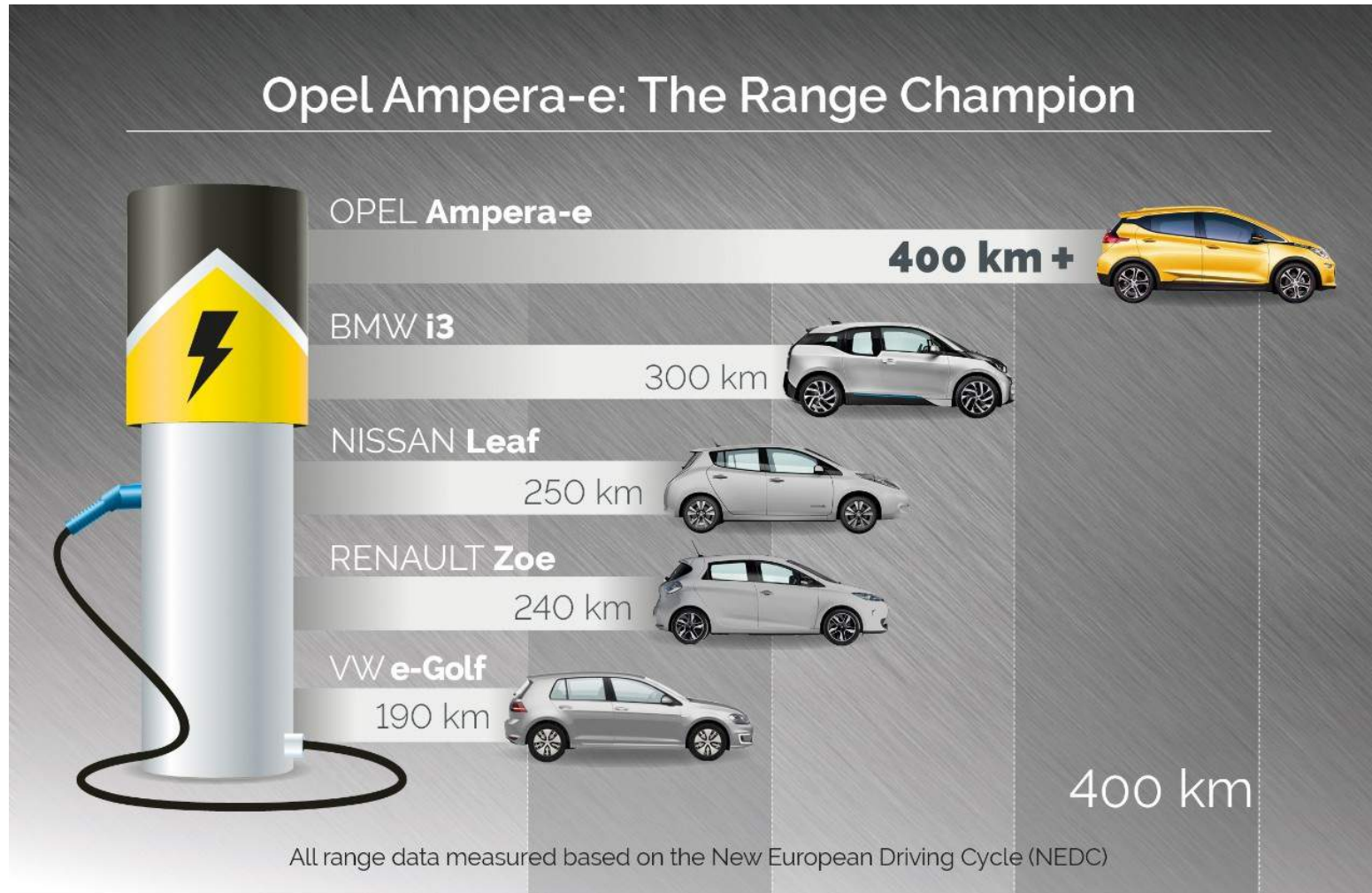

Tesla Model S bate recorde de autonomia: 1078 km percorridos

Publicado a 2017-08-07 por AutoMonitor

Principais barreiras têm vindo a ser ultrapassadas

Can Falling Battery Prices Push Electric Cars?

Most commonly cited barriers to purchase an electric vehicle
% of responses from potential EV buyers in the U.S. and Germany

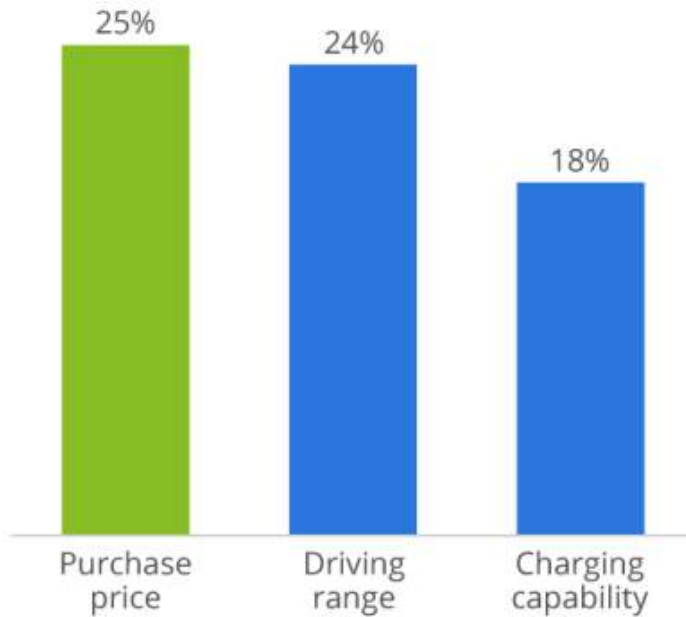

Average battery pack price (\$ per kWh)

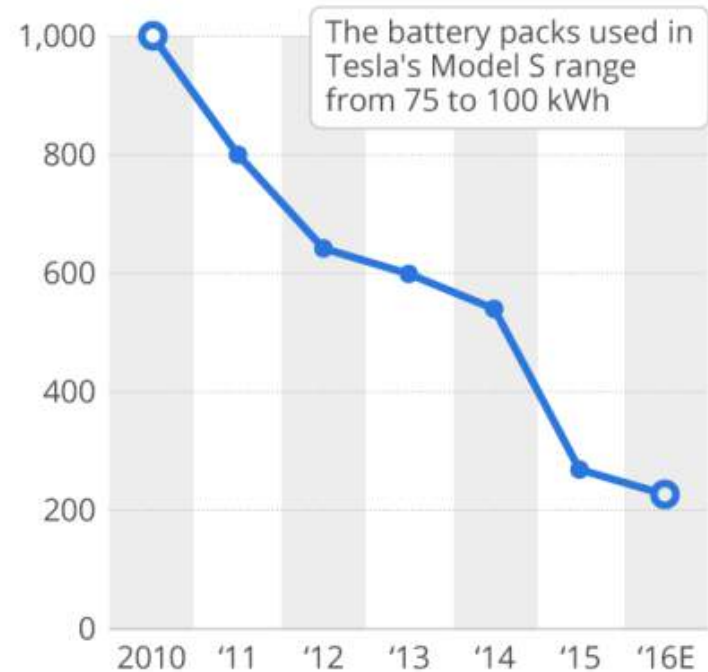

Price parity em 2025

Elon Musk afirmou há dias que o Model S alcançará os **1.200 km de autonomia** em 2020.

Recarga indutiva SAE J2954

3. O ponto fraco é ainda a bateria

- Para maximizar a eficiência os VE são otimizados ao nível da:
 - Diminuição do **peso** (recurso a materiais mais leves);
 - Melhoria do **perfil aerodinâmico**;
 - Mitigação do **atrito de rolamento** com novos tipos de pneus;
 - Maximização da conversão de energia eléctrica em energia mecânica e
 - Maximização da **capacidade regenerativa**.



Mercedes Benz targets 0.20Cd drag coefficient in next five years

4. Comparação das arquiteturas dos veículos automóveis

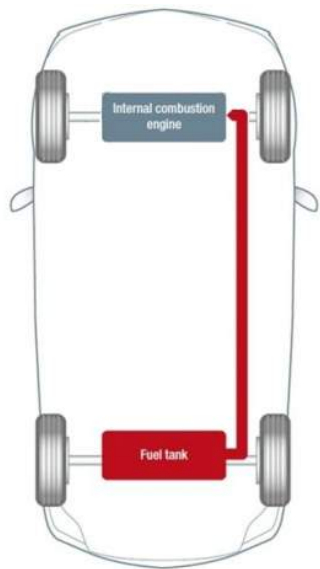

ICE
Internal Combustion
Engine

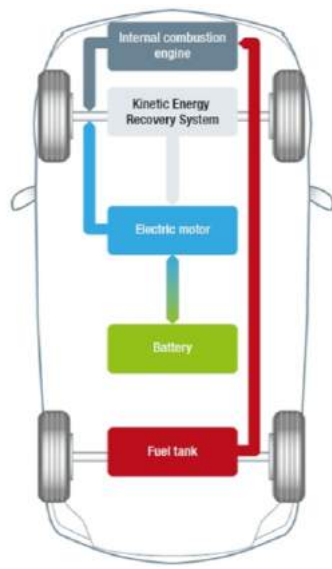

HEV
Hybrid Electric
Vehicle

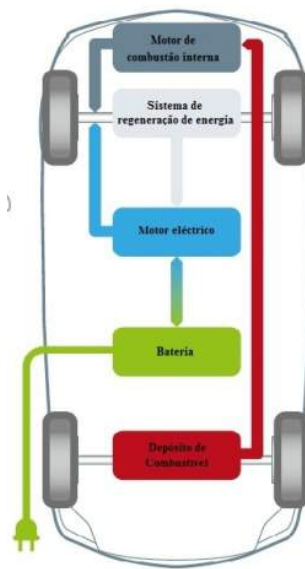

PHEV
Plug-In Hybrid Electric Vehicle
(Parallel and Series Hybrid with
Range Extender)

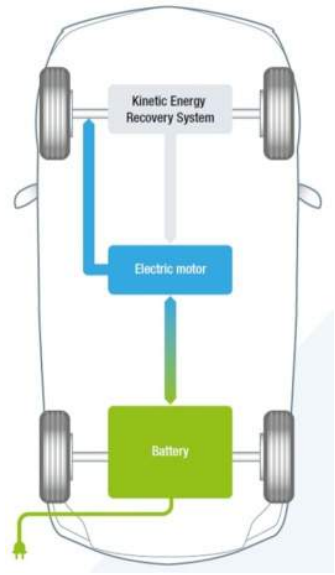
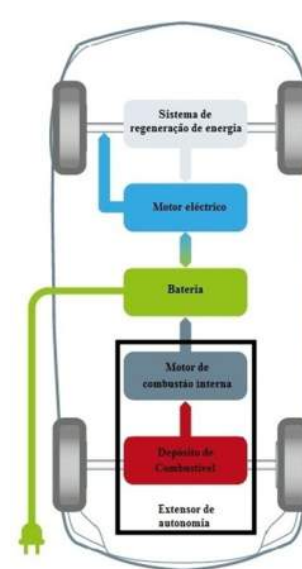

BEV
Battery
Electric Vehicle

Arquitectura híbrida paralela (HEV)

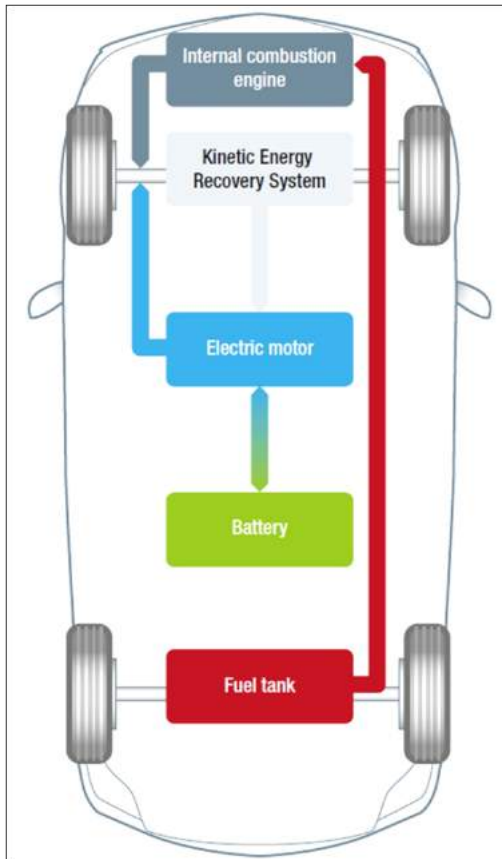

HEV
Hybrid Electric
Vehicle

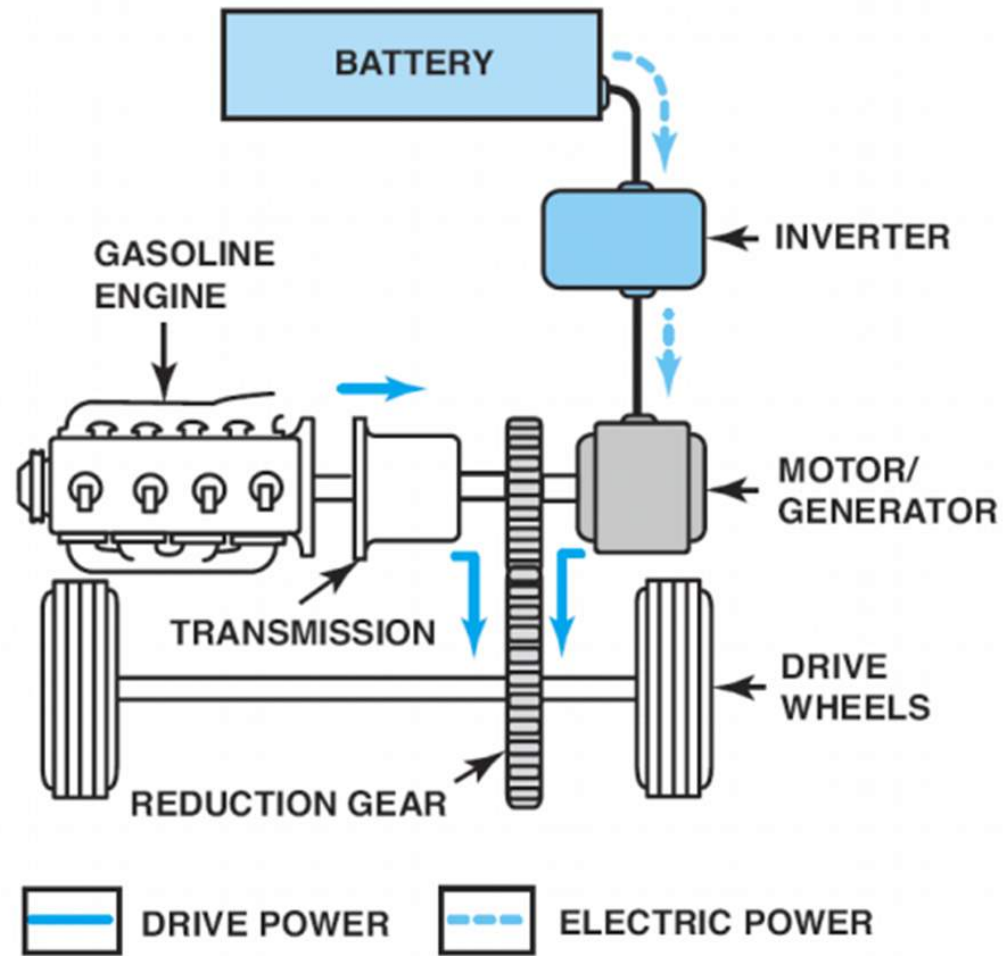

Arquitectura híbrida paralela - Toyota Prius

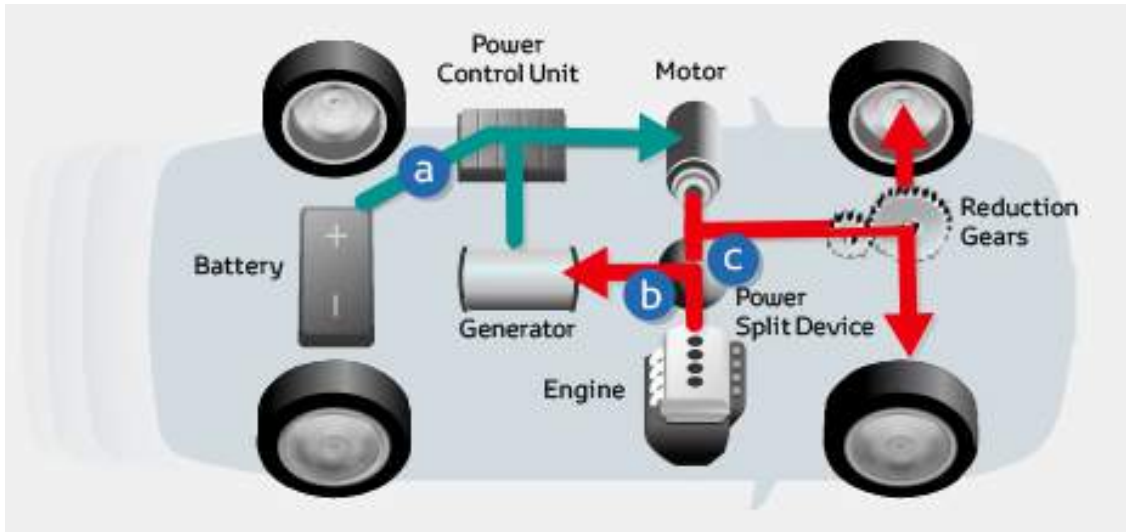

Arquitectura híbrida paralela - Honda Civic IMA

(Integrated Motor Assist)

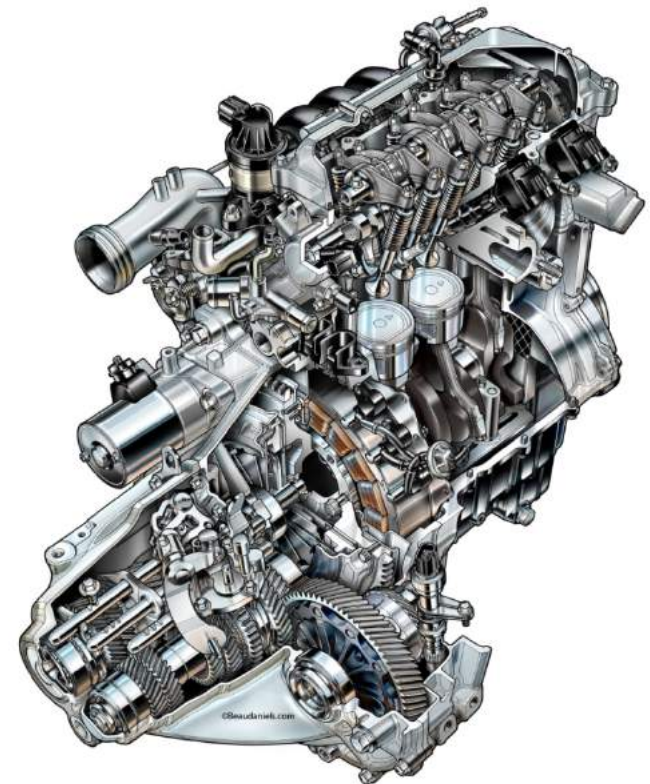
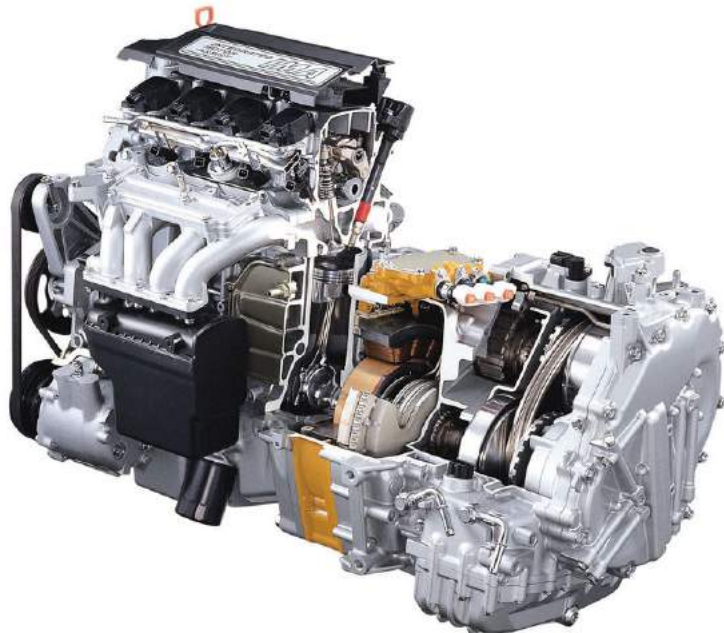
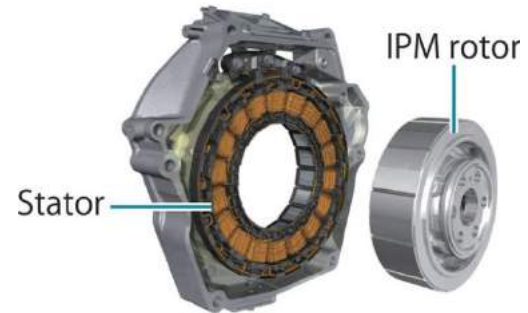

Arquitectura híbrida paralela - Lexus

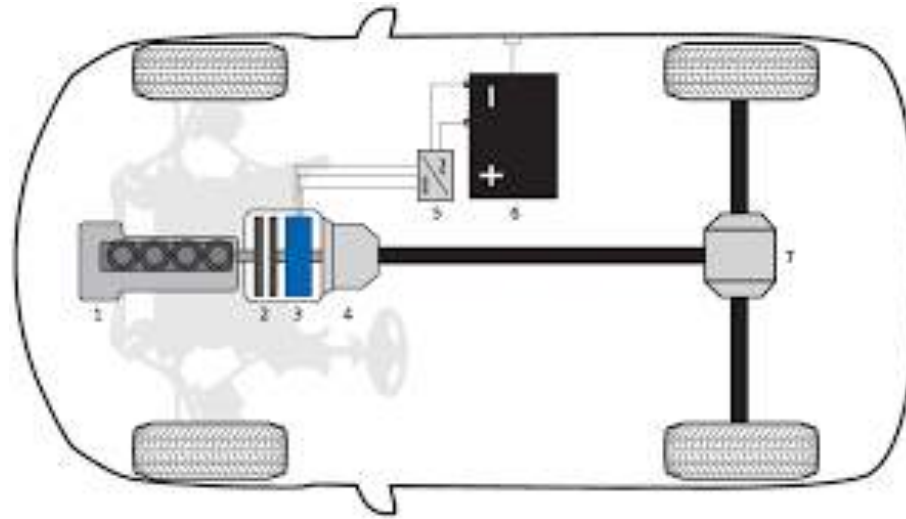

Arquitetura híbrida paralela (HEV) com Plug-In

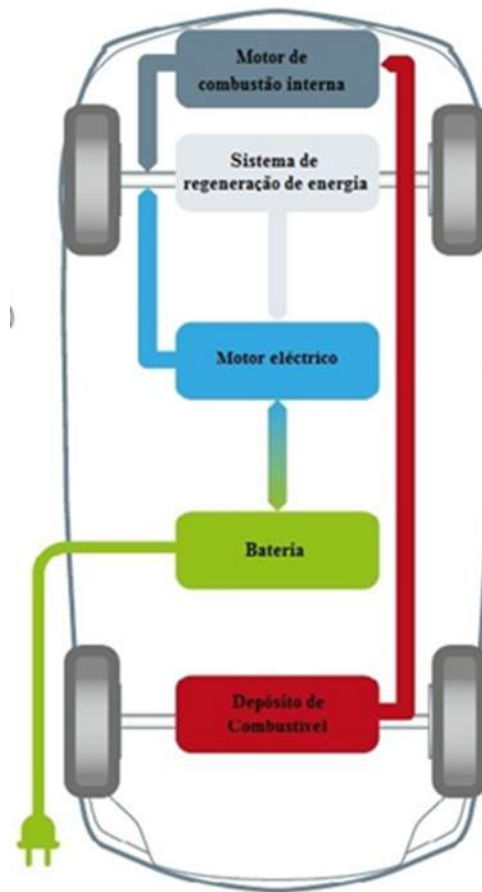

PHEV
Parallel Hybrid
with Plug-In

Arquitectura híbrida paralela (PHEV) - exemplos

BMW e330



VW Golf GTE

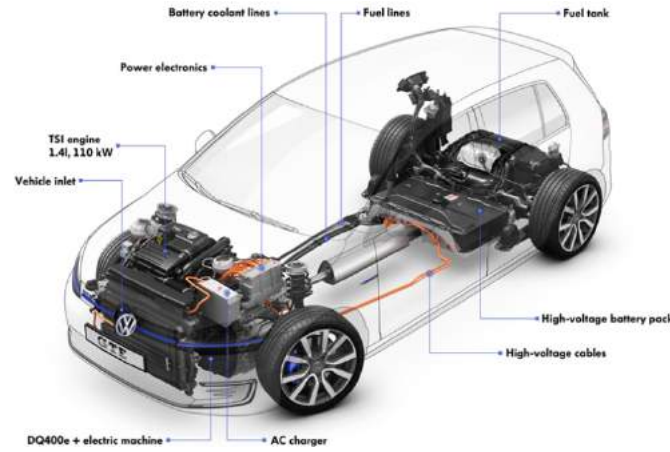

BMW i8

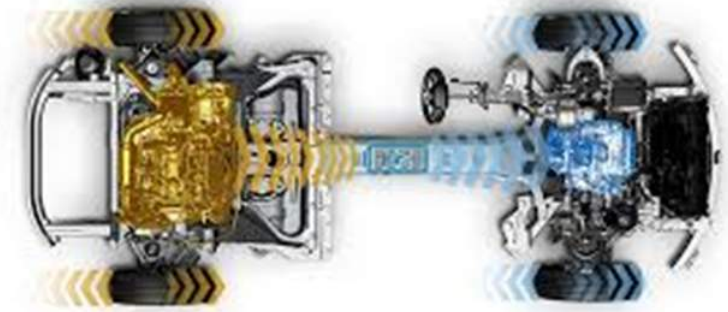

VW Golf GTE



VW Golf GTE



Peugeot 508 Híbrido



Arquitetura híbrida série

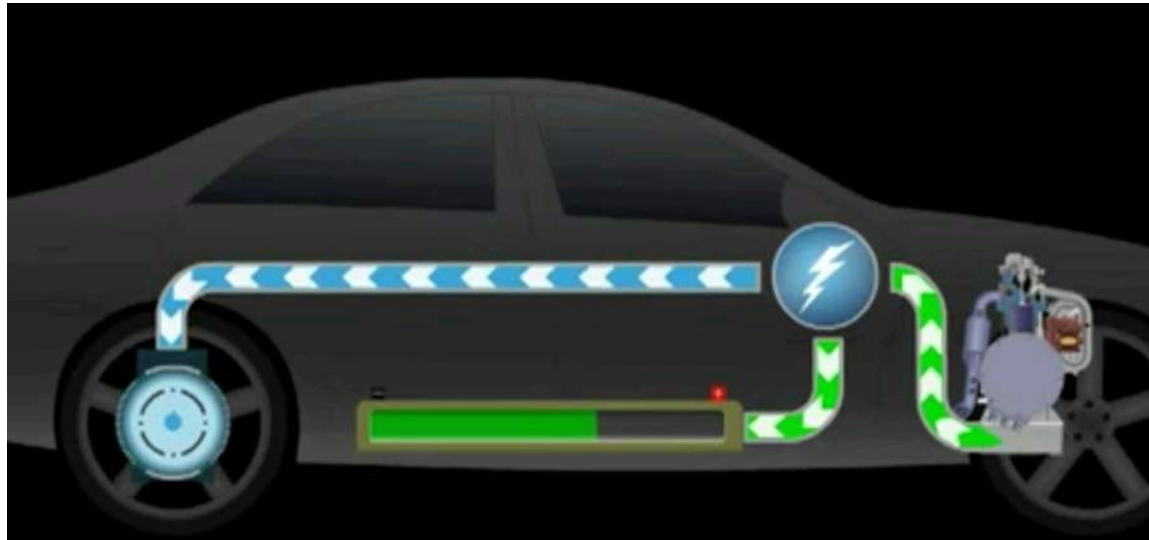

BMW i3 RE – Plug-In Hybrid Electric Vehicle (PHEV - RE)

Arquitetura Elétrica Pura (BEV)

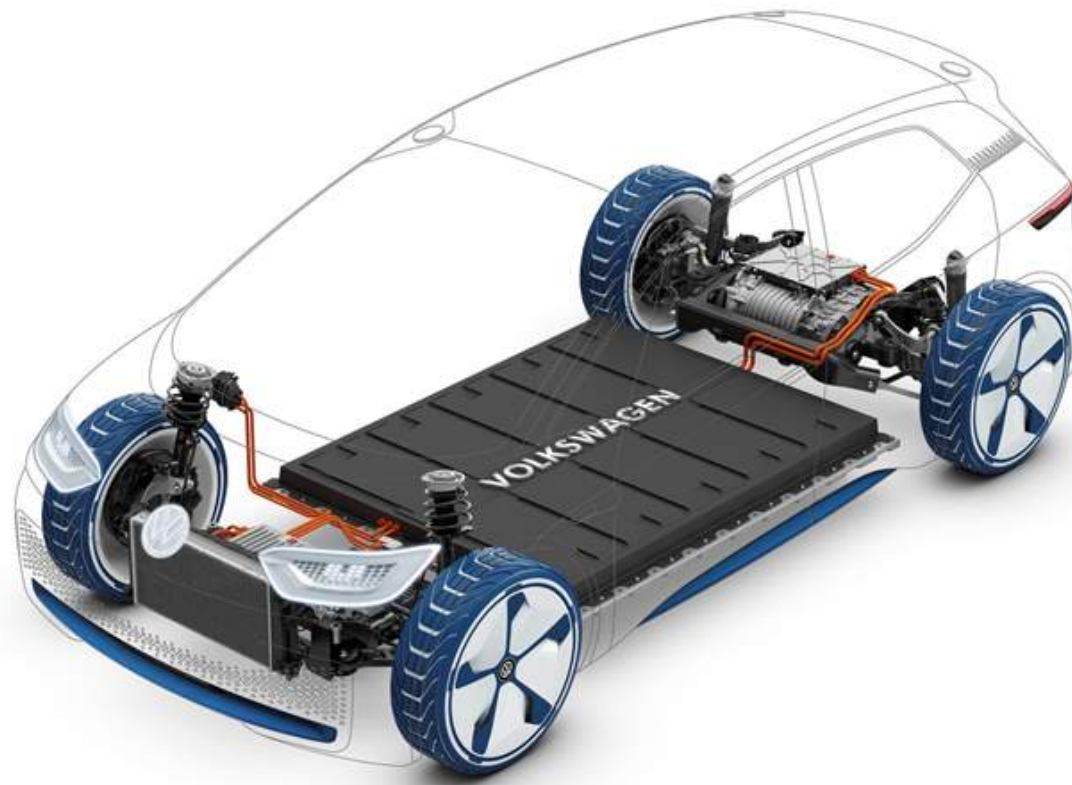
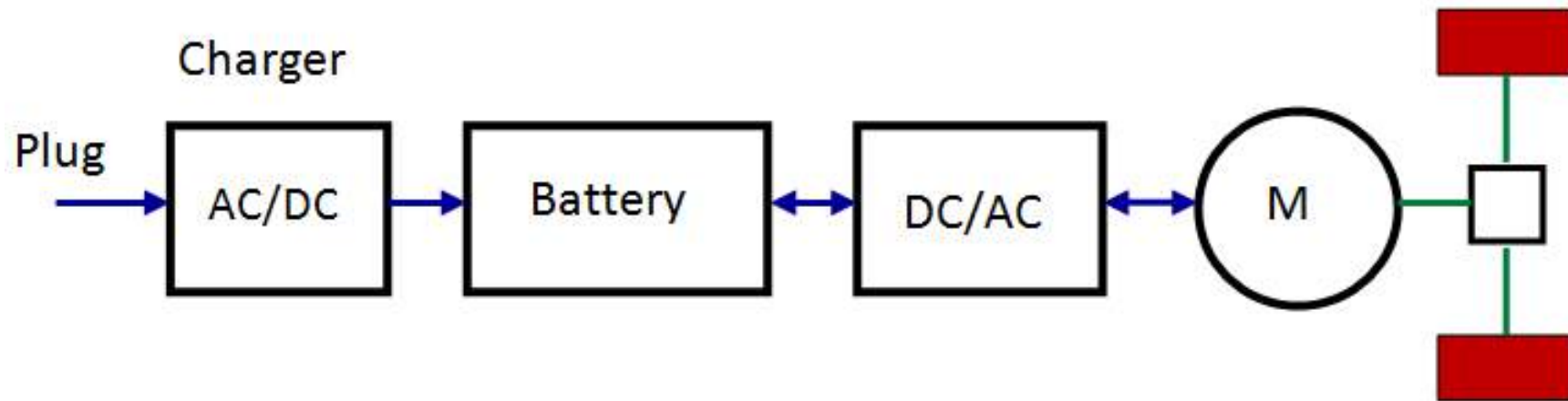

Arquitetura híbrida mista – VOLTEC

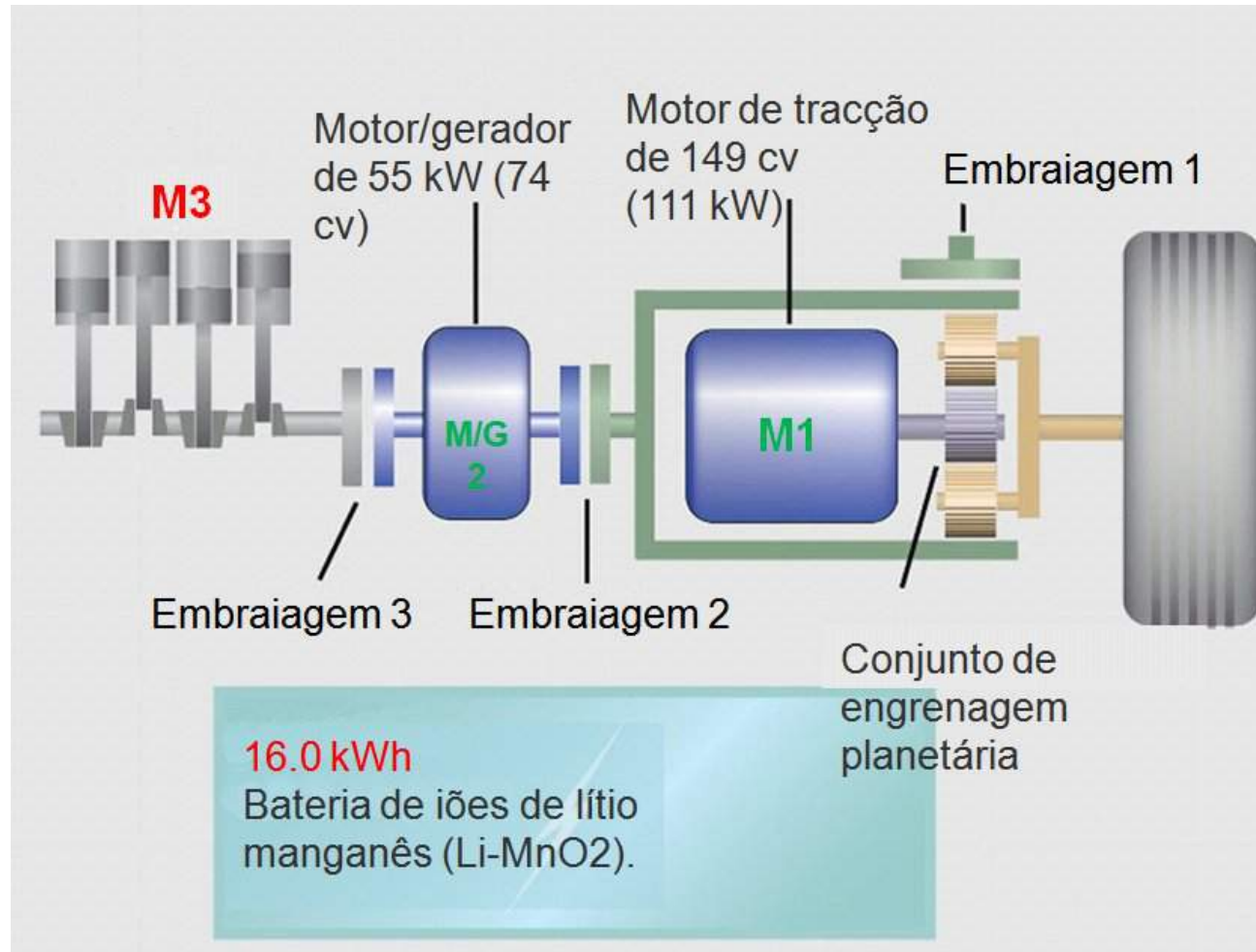

Opel Ampera e Chevrolet Volt

Funcionamento da arquitetura VOLTEC

Modo 1

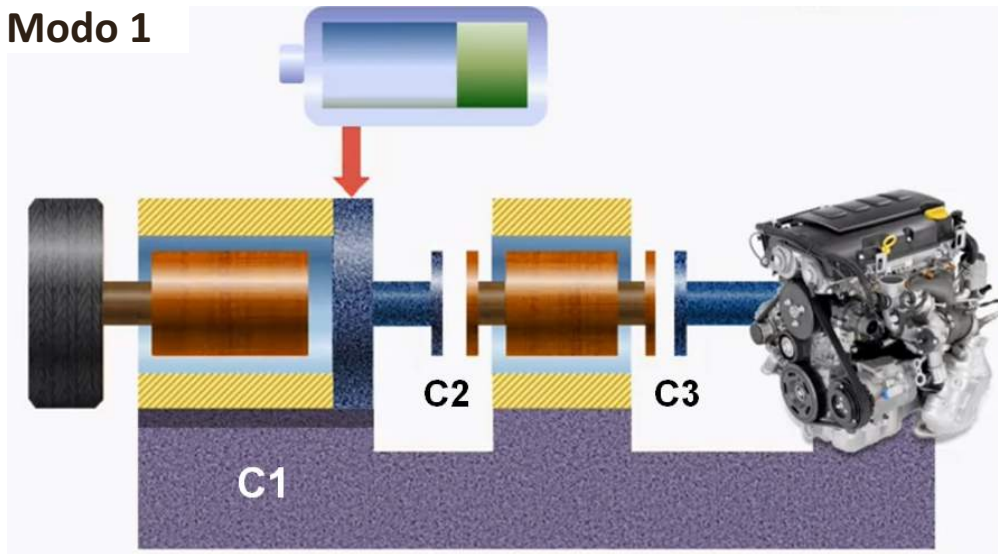

Modo 2

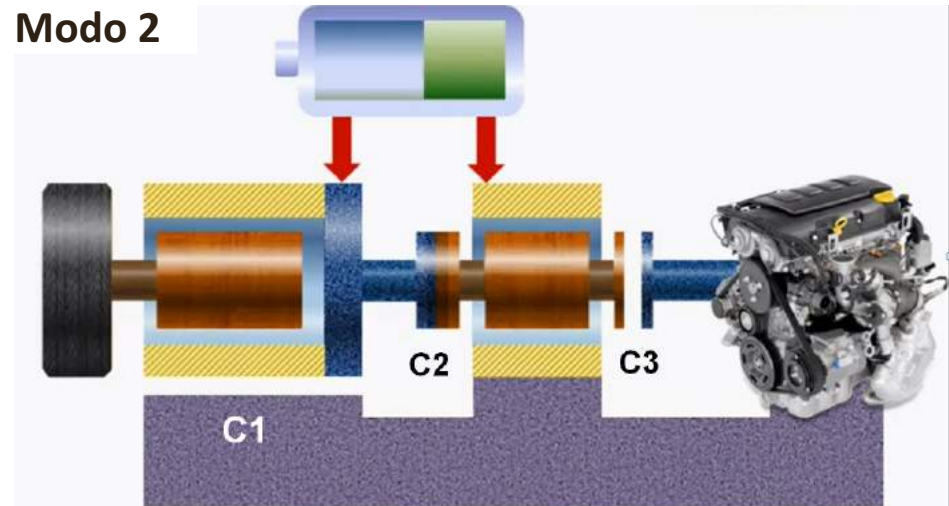

Modo 3

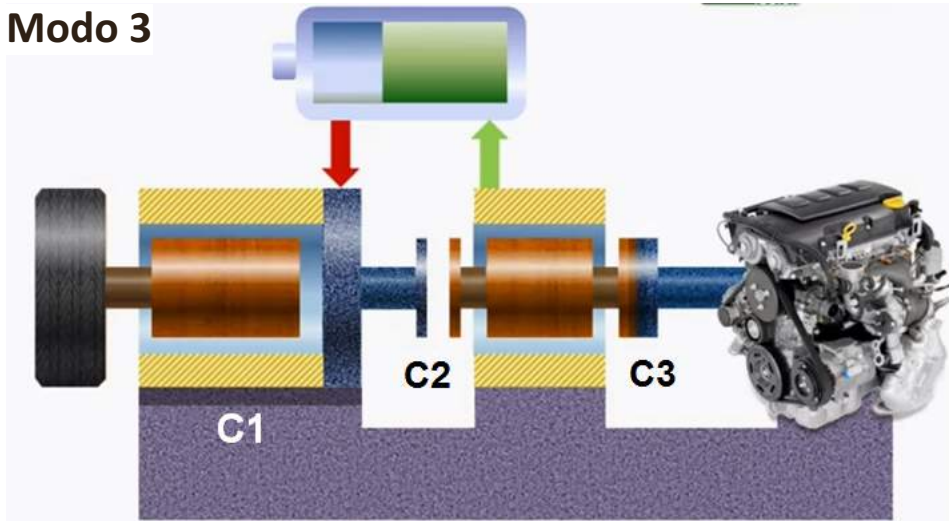

Modo 4

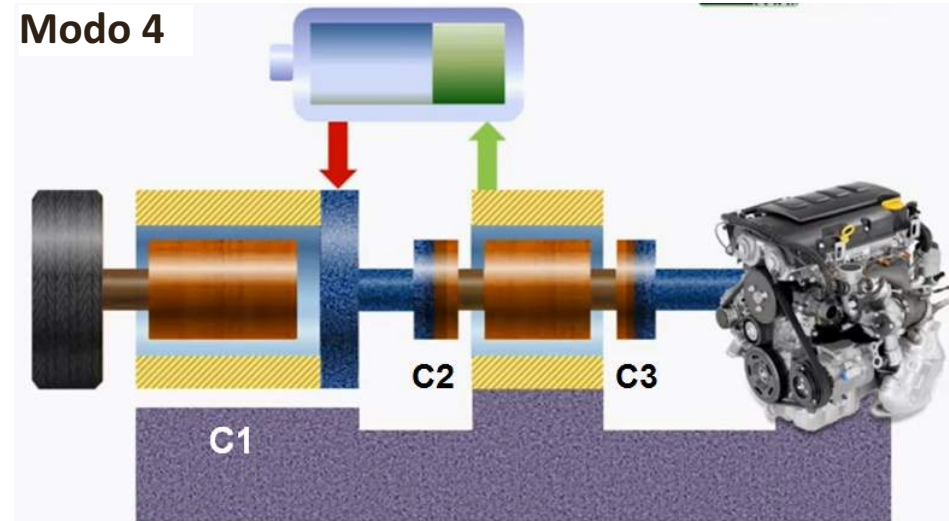

Componentes da arquitetura VOLTEC

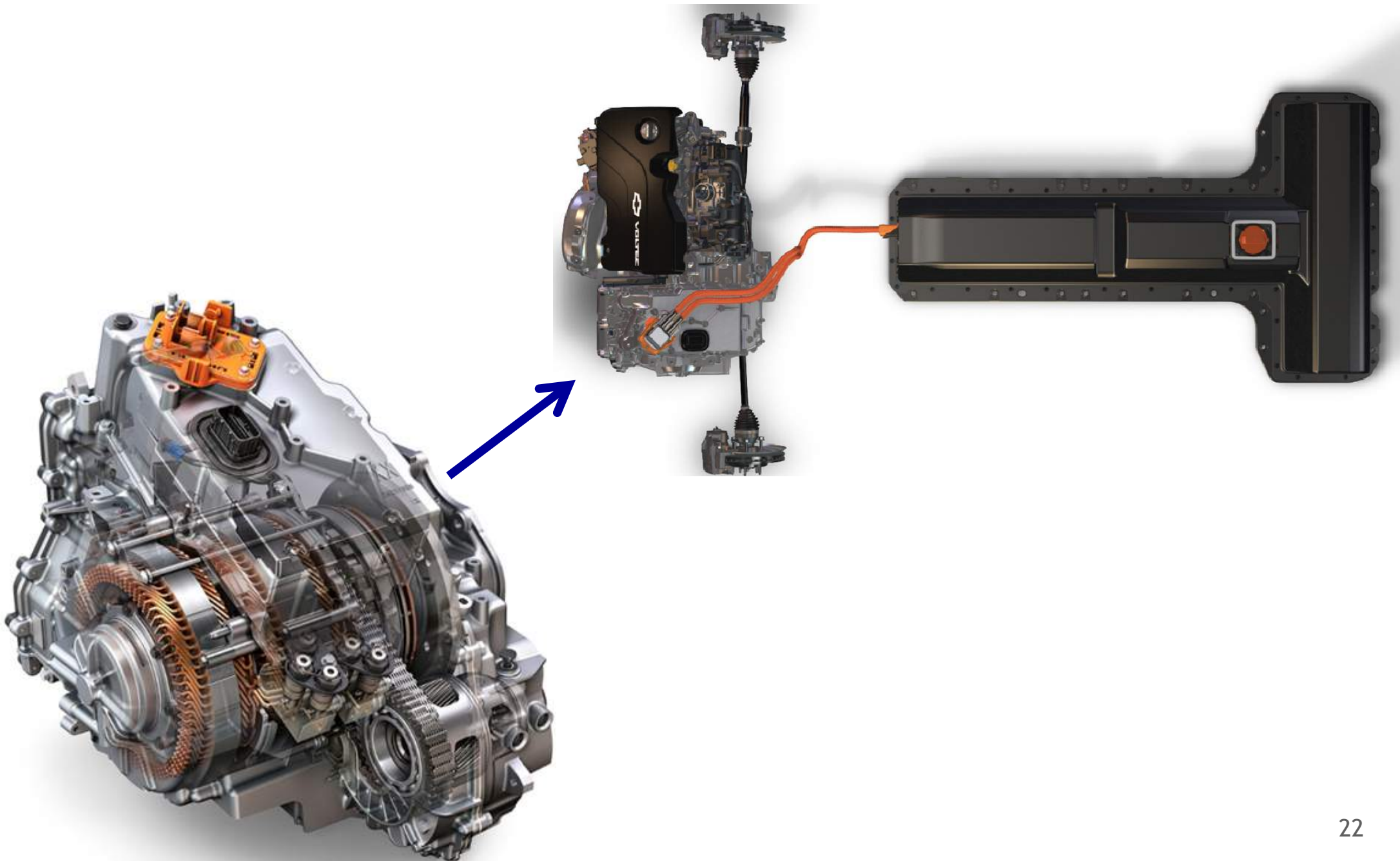

Mild hybrid – 48 V (Hibridização do MCI convencional)

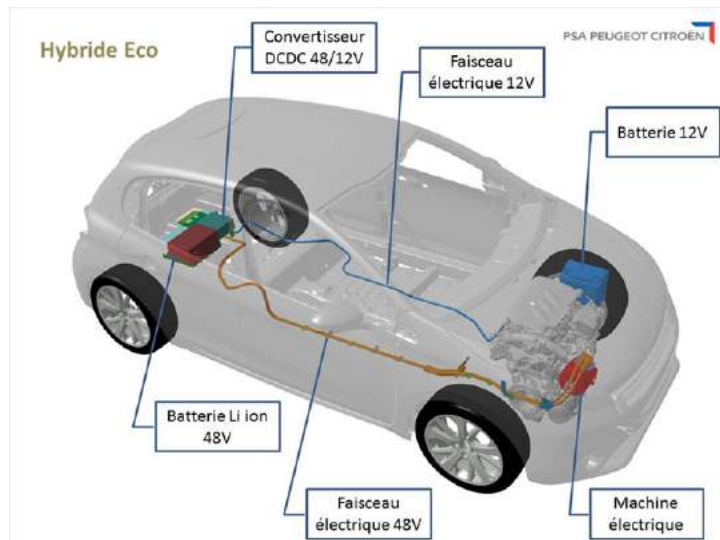
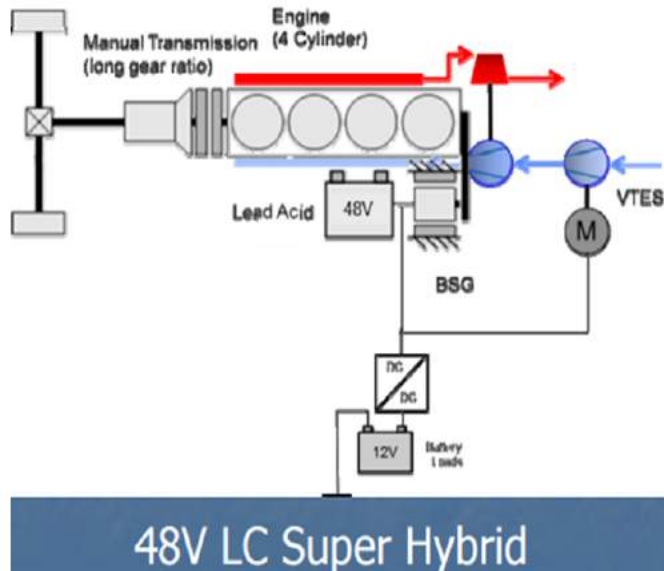

Eco Hybrid do grupo PSA

Great Benefit at a Low Cost

Though a mild hybrid can be configured in many ways, here is one example of a cost effective, lower CO₂ emitting, 48-volt mild hybrid using Stop/Start and regenerative braking.

THE 48-VOLT BATTERY PACK

- 1 AC/DC converter changes AC generator current to DC battery current
- 2 48-volt lithium ion battery charges and discharges at every stop and start
- 3 Battery controller regulates the state of charge in the battery

STEPPING DOWN TO 12-VOLT

- 4 DC/DC converter changes 48-volt battery power to run the 12-volt accessories
- 5 12-volt battery – your old friend
- 6 12-volt electrical distribution center for 12-volt electrical devices like the center console, power seats and windows sensors, etc.

THE BRAIN

Hybrid controller tells the engine controller when to stop and start, tells the motor/generator when to charge the battery or propel the car

48-volt, mild hybrids have demonstrated to have ...

70% of the **BENEFIT** of high voltage mild hybrids @ **30%** of the **COST** of high voltage mild hybrids

THE 48-VOLT MACHINES

- 7 Electric motor/generator starts engine, then helps the car to get going. Later charges the battery during braking
- 8 Electrical supercharger starts providing boost before engine starts, eliminating turbo lag

Tesla Semi ... (26.10.17)

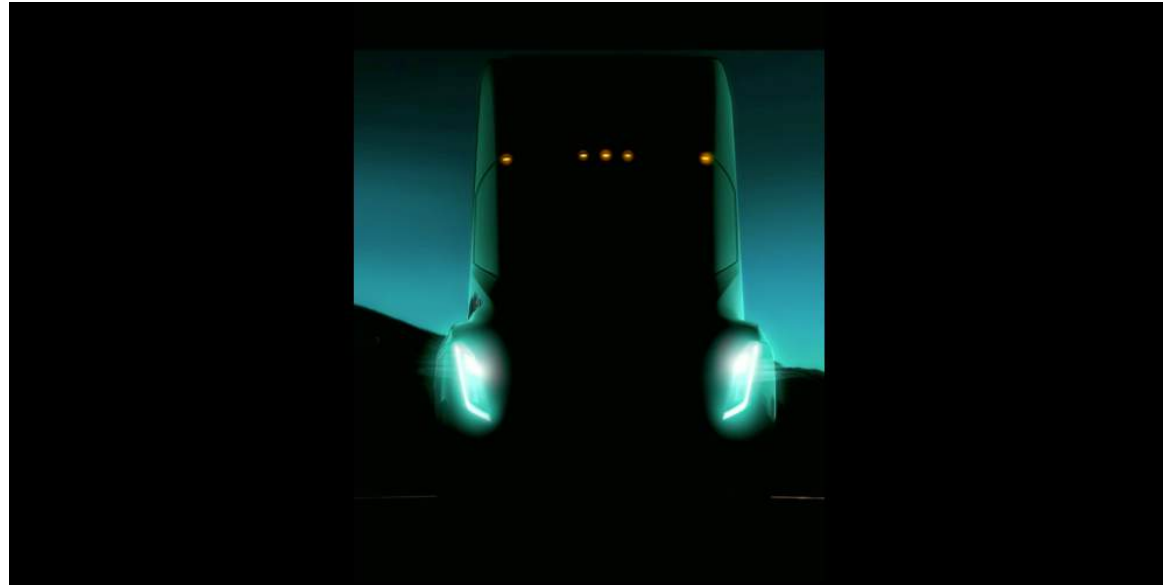

Alice electric airplane + Lilium electric táxi (...)

An electric aircraft designed to take 9 passengers up to 1,000km at more than 240kts

